

Part Number	Port Siz (NPT)	Set Point Range	
		BAR	psig
T-70	960-129-000	1/4"	0-0.1 0-2
	960-174-000	3/8"	0-0.1 0-2
	960-162-000	1/2"	0-0.1 0-2
	960-130-000	1/4"	0-0.7 0-10
	960-131-000	3/8"	0-0.7 0-10
	960-163-000	1/2"	0-0.7 0-10
	960-089-000	3/8"	0-2.1 0-30
	960-090-000	1/4"	0-2.1 0-30
	960-159-000	1/2"	0-2.1 0-30
	960-091-000	3/8"	0.1-4.1 1-60
	960-092-000	1/4"	0.1-4.1 1-60
	960-160-000	1/2"	0.1-4.1 1-60
	960-093-000	3/8"	0.1-10.3 2-150
	960-094-000	1/4"	0.1-10.3 2-150
	960-161-000	1/2"	0.1-10.3 2-150
960-152-000	1/4"	0.2-13.8 3-200	
960-153-000	3/8"	0.2-13.8 3-200	
960-164-000	1/2"	0.2-13.8 3-200	
T-70BP	960-191-000	1/4"	0-0.1 0-2
	960-192-000	3/8"	0-0.1 0-2
	960-194-000	1/4"	0-0.7 0-10
	960-195-000	3/8"	0-0.7 0-10
	960-197-000	1/4"	0-2.1 0-30
	960-198-000	3/8"	0-2.1 0-30
	960-200-000	1/4"	0-4.1 0-60
	960-201-000	3/8"	0-4.1 0-60
	960-203-000	1/4"	0-10.3 0-150
	960-204-000	3/8"	0-10.3 0-150

OPTIONS		
Type	70	70BP
2 Non-Relieving	.	.
3 Knob	s	s
Sq. Head Adj. Screw	.	.
5 Epoxy Coating	.	.
6 Tapped Vent	.	.
7 Mounting Bracket	.	.
8 Pressure Gauge	.	.
9 Tamper - Resistant Cover	.	.
10 Low Bleed	.	.
11 Check Valve	.	.

OPTION ORDERING MATRIX:

Add three digits from table below to end of part number.

OPTION	2	3	5	6	7	8	9	10	11
2 Non-Relieving	002	032	052	062	072	082	092		112
3 Sq. head Adj. Screw		003	053	063	073	083		103	113
5 Epoxy Coating			005	065	075	085	095	105	115
6 Tapped Vent				006	076	086	096	106	116
7 Mounting Bracket					007	087	097	107	117
8 Pressure Gauge						008	098	108	118
9 Tamper-Resistant Cover							009	109	119
10 Low Bleed								010	110
11 Check Valve									011

REGULATOR OPTIONS & ACCESSORIES
NON-RELIEVING

Used in applications where it is desirable to relieve pressure downstream of the regulator, for some constant flow applications, and where the gas flowing through the regulator must not escape at the regulator. Non-relieving regulators should not be used for low or no flow applications.

CORROSIVE RESISTANT EPOXY FINISH

An epoxy paint applied to the body and dripwell of the regulator exterior surfaces to provide increased corrosion resistance.

TAPPED VENT

Allows installation of plumbing to capture exhaust air.

MOUNTING BRACKET

Steel (dichromate finish) bracket for side mounting.

PRESSURE GAUGE

Dual scale 2 in. (50.8 mm) gauges. Ranges include 0-30 psig (0-200 kPa), 0-60 psig (0-400 kPa), 0-100 psig (0-700 kPa) and 0-160 psig (0-1100 kPa). When specified with regulator, the correct range will be supplied.

TAMPER-RESISTANT COVER

An aluminum tubular cover placed over a slotted head adjusting screw and screwed onto the bonnet of the regulator with a wrench. Prevents ordinary hand adjustments.

LOW BLEED

Reduces steady-state air consumption by approximately 50%.

CHECK VALVE

Allows quick dumping of output line pressure through the supply air line when the supply is shut down.

IMPORTANT NOTICE Our recommendations, if any for the use of this product are based on tests believed to be reliable. The greatest care is exercised in the selection of our raw materials and in our manufacturing, no guarantee or warranty, express or implied, is made as to such use or effects incidental to such use, handling or possession or the results to be obtained, whether in accordance with the directions or claimed so to be. The manufacturing expressly disclaims responsibility therefor. Furthermore, nothing contained herein shall be construed as a recommendation to use any product in conflict with existing laws and/or patents covering any material use.



Type-70

High Flow Precision Pressure Regulators & Back-Pressure Regulators



Precision Control Devices

ISO 9002 certified

Type-70 High Flow Air Pressure Regulator

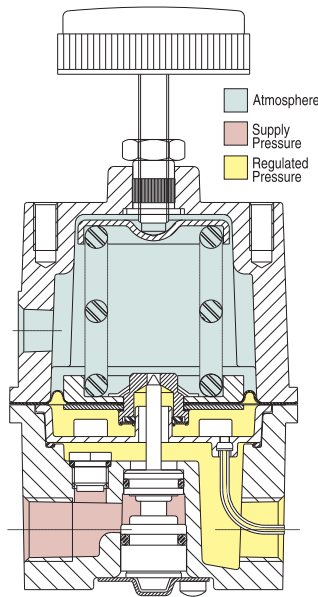

FEATURES

- High flow capacity - Up to 80 SCFM (2266 LPM)
- Responds quickly to minute changes in downstream pressure
- Dampening action of aspirator tube maintains downstream pressure
- Balanced supply valve minimizes the effect of supply pressure changes
- Bellofram's Buna-N and polyester rolling diaphragms are designed to provide millions of cycles
- Honking & buzzing eliminated by action of integral baffle and aspirator tube
- Stack up construction can be disassembled and serviced without removal from air line

DESCRIPTION

The Type-70 Regulator is specifically designed for applications that require substantial flow capacity and accurate pressure controls. Flows of 80 SCFM (2250 LPM) can be attained. Downstream pressure can be set within 0.25 in. (6.3mm) of water column and is accurately maintained under varying flow conditions with the help of an aspirator tube which adjusts the air supply in accordance with the flow velocity. A balanced supply valve, utilizing a rolling diaphragm, makes the regulator virtually immune to changes in supply pressure.

The Type 70 has a rugged precision die-cast aluminum housing, and is pressure-tested and chromate-treated for internal corrosion resistance. The regulator housing is finished with vinyl paint which resists scratching, weathering and other physical abuse.



Type-70 High Flow Back Pressure Air Regulator

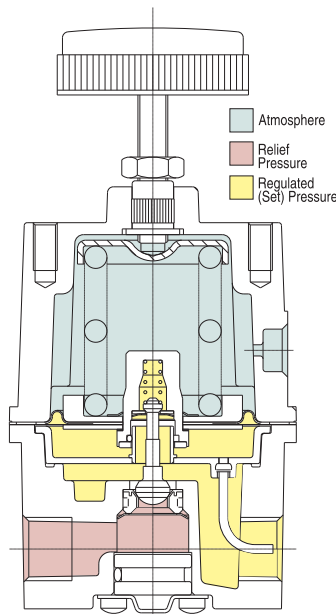

FEATURES

- High flow Capacity - Up to 50 SCFM (1400 LPM)
- Responds quickly to minute changes in upstream pressure
- Bellofram's Buna-N and polyester rolling diaphragms are designed to give millions of cycles
- Stack up construction can be disassembled and serviced without removal from air line

DESCRIPTION

The Type-70 Back-Pressure Regulator functions as a high flow high precision pneumatic relief valve with an adjustable setpoint. The Type-70BP can be used in place of a standard relief valve to improve pressure control while maintaining protection against over pressurization, as in supply pressure lines to instruments and other control devices.

It is most often used in conjunction with a diaphragm-operated valve and bleed orifice as a compressor controller. Excess compressor pressure is relieved through the regulator to actuate the intake restricting valve. When the regulator is shut off, downstream air escapes through the bleed orifice, allowing the restricting valve to open.

	TYPE 70 Regulator	TYPE 70BP Regulator
Sensitivity	1/4" (6.4 mm) Water Column	1/8" (3.2 mm) Water Column
Flow Capacity	40, 50, or 80 SCFM (1113, 1416, 2266 LPM)	50 SCFM (1416 LPM)
Effect of Supply Pressure variation (25 psig) on Outlet Pressure	< 0.025 psig (1.7 BAR)	N/A
Exhaust Capacity (5 psig above 20 psig set point)	4 SCFM (113 LPM)	N/A
Maximum Input / Supply Pressure	250 psig (17.2 BAR)	250 psig (17.2 BAR)
Effect of Changes in Flow on Regulated Pressure (100 psig/6.9 BAR Supply)	2.5 psig (0.2 BAR) over flow 50 SCFM (1416 LPM) (3/8" NPT, 0-30 psig / 0-2.1 BAR range, 15 psig / 1 BAR set point)	N/A
Output Pressure Ranges (Type 70)	0-2 psig, 0-10 psig, 0-30 psig, 1-60 psig, 2-150 psig, 3-200 psig 0-0.1 BAR, 0-0.7 BAR, 0-2.1 BAR, 0.1-4.1 BAR 0.1-10.3 BAR, 0.2-13.8 BAR	N/A
Set Point Ranges (Type 70BP)	N/A	0-2 psig, 0-10 psig, 0-30 psig, 0-60 psig, 0-150 psig 0-0.1 BAR, 0-0.7 BAR, 0-2.1 BAR, 0-4.1 BAR, 0-10.3 BAR
Total Air Consumption @ Maximum Output	from 1.0 to 12.5 SCFH (0.5-6 LPM)	N/A
Temperature Range	-40° to 200° F (-40° to 93° C)	-40° to 200° F (-40° to 93° C)
Port Size	1/4", 3/8", 1/2" NPT, BSPT	1/4", 3/8", 1/2" NPT, BSPT
Size	3.0" X 3.0" X 6.0" (76 X 76 X 152 mm)	3.0" X 3.0" X 6.0" (76 X 76 X 152 mm)
Weight	1.41 lb. (0.6 kg)	1.5 lb. (0.7 kg)
Materials of Construction	Body: Diecast aluminum with vinyl paint Adjusting Screw: Plated steel Trim: Plated steel, brass, acetal resin Diaphragm: Buna-N with polyester fabric Knob: Phenolic plastic Spring: Music wire	Body: Diecast aluminum with vinyl paint Adjusting Screw: Plated steel Trim: Acetal, brass, plated steel, nitrile Diaphragm: Buna-N with polyester fabric Knob: Phenolic plastic Spring: Music wire
Preset Pressure	No	No
Tamper-Resistant Cover	Yes	Yes
Mounting	Pipe, panel, or bracket	Pipe, panel, or bracket

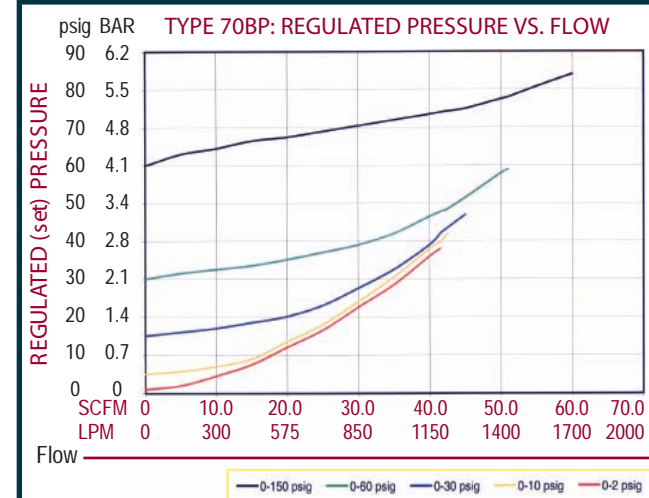
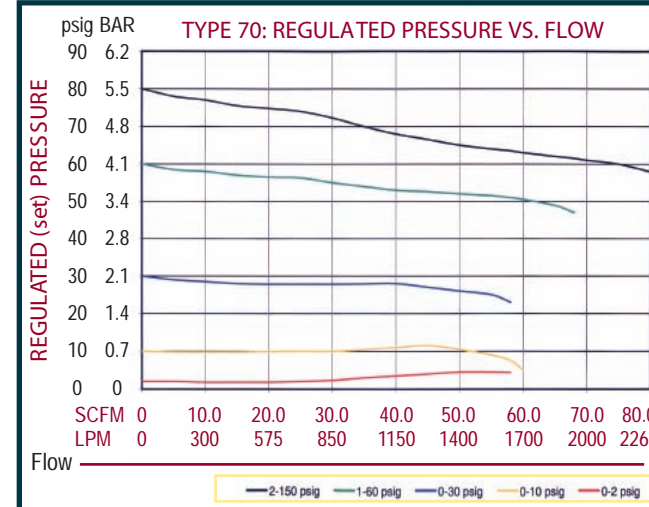

Dimensions for Type-70 & Type-70BP

