

**mB** **MARSH BELLOFRAM**<sup>®</sup>

Precision  
Control  
Devices



# Type-60 Type-65

General  
Purpose  
Pre-Set  
Air Regulators



**mB** T-60 & T-65 General Purpose Pre-Set Air Regulators

## FEATURES

- Pre-Set, ideal for OSHA regulations
- Superior regulation characteristics
- Rugged, corrosion-resistant construction
- Excellent stability and repeatability
- Self-relieving
- Low droop at high flow
- Several mounting options
- Low cost

## APPLICATIONS

The design of these regulators is especially well suited to pilot-operated controllers, and instruments, as well as applications such as air chucks, air spray guns, air cylinders and actuators, and a wide range of industrial pneumatic systems and equipment.

## DESCRIPTION

Marsh Bellofram's General Purpose Type 60 & Type 65 Precision Air Regulators are reliable precision units designed for instrumentation and general purpose use. The Type 60 is a pre-set, fixed-pressure unit with a dripwell. The Type 65 is similar to the Type 60, but without a dripwell.

Test data for these regulators show excellent performance characteristics compared with those of similar units presently on the market. These Marsh Bellofram regulators are generally superior in regulated pressure vs. flow, forward-to-reverse flow offset, supply pressure sensitivity, repeatability and stability.

Ruggedly designed and constructed, the regulators have housings of diecast aluminum. Both models are finished with vinyl paint (which resist scratching, weathering and other physical abuse), and are pressure and leak tested prior to shipment from the factory.

Careful design and quality materials throughout assure long, trouble-free operation in the most difficult industrial environments. A rubberized, soft-seat valve stem provides positive shut-off and "forgives" dirt or other foreign matter. An aspirator maintains downstream pressure and compensates for droop when high flow occurs. The gauge port is convenient for gauge installation and can also be used as an additional full flow outlet.

The Type 65 regulator has a 60-mesh 304 stainless steel screen to block foreign particles from entering the output stream. The Type 60 regulator has a unique self-cleaning nylon 40 micron mesh filter that can be easily removed. Type 60 and Type 65 tamperproof regulators meet OSHA requirements for air supplied to hand-held air guns (if preset to 30 psig).

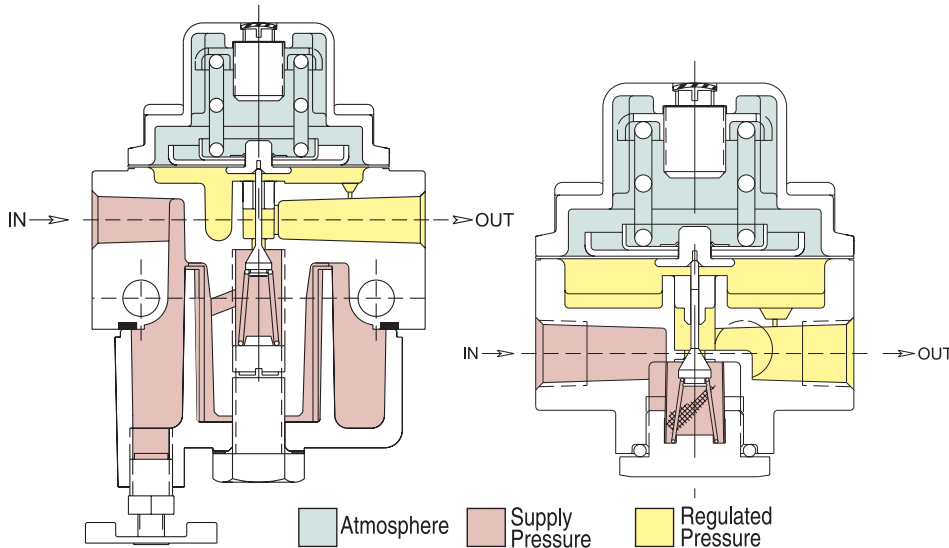

	<b>TYPE 60 Regulator</b>	<b>TYPE 65 Regulator</b>
Sensitivity	1" (25.4 mm) Water Column	1" (25.4 mm) Water Column
Flow Capacity @ 100 psig (6.9 BAR) supply 20 psig (1.4 BAR) outlet	20 SCFM ( 565 LPM)	20 SCFM ( 565 LPM)
Effect of Supply Pressure variation (25 psig) on Outlet Pressure	< 0.2 psig (0.01 BAR) for 25 psig (1.7 BAR)	< 0.2 psig (0.01 BAR) for 25 psig (1.7 BAR)
Exhaust Capacity (5 psig above 20 psig set point)	0.1 SCFM (2.8 LPM)	0.1 SCFM (2.8 LPM)
Maximum Input / Supply Pressure	250 psig (17.2 BAR)	250 psig (17.2 BAR)
Effect of Changes in Flow on Regulated Pressure (100 psig/6.9 BAR Supply)	3 psig (0.2 BAR) for 10 SCFM ( 283 LPM) (1/4" NPT, 20 psig / 1.4 BAR set point)	3 psig (0.2 BAR) for 10 SCFM ( 283 LPM) (1/4" NPT, 20 psig / 1.4 BAR set point)
Output Pressure Ranges	0-20 psig (0-1.4 BAR) 20-40 psig (1.4-2.8 BAR) 40-60 psig (2.8-4.1 BAR)	0-20 psig (0-1.4 BAR) 20-40 psig (1.4-2.8 BAR) 40-60 psig (2.8-4.1 BAR)
Total Air Consumption @ Maximum Output	6 SCFH (2.8 LPM)	6 SCFH (2.8 LPM)
Port Size	1/4" NPT, BSPT	1/4" NPT, BSPT
Size	3.19" X 3.19" X 4.70" (81 X 81 X 119 mm)	2.5" X 2.5" X 3.13" (64 X 64 X 80 mm)
Weight	1.59 lb. (0.7 kg)	0.69 lb. ( 0.3 kg)
Materials of Construction	Body: Diecast aluminum with vinyl paint Adjusting Screw: Plated steel Trim: Plated steel, brass, acetal resin Diaphragm: Buna-N elastomer with polyester fabric Spring: Music wire	Body: Diecast aluminum with vinyl paint Adjusting Screw: Plated steel Trim: Plated steel, brass, acetal resin Diaphragm: Buna-N elastomer with polyester fabric Spring: Music wire
Mounting	Pipe, Bracket or Thru Body Holes	Pipe or Bracket

**T-60 & T-65 SPECIFICATIONS**

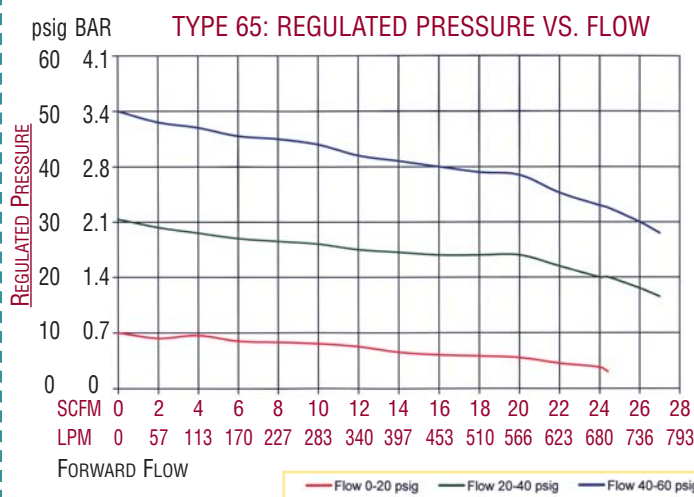
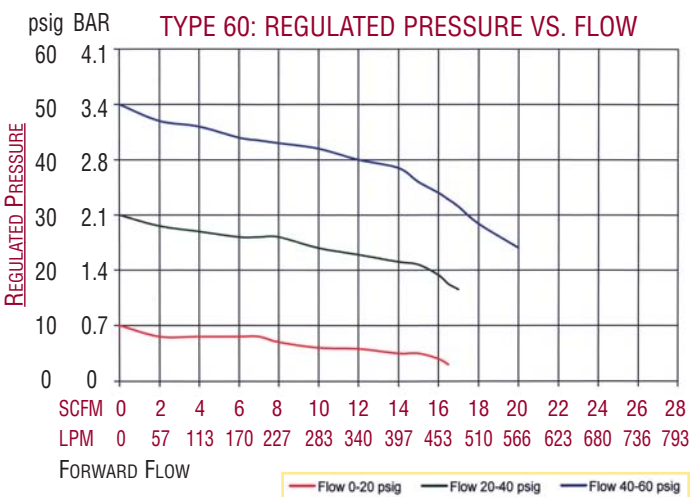
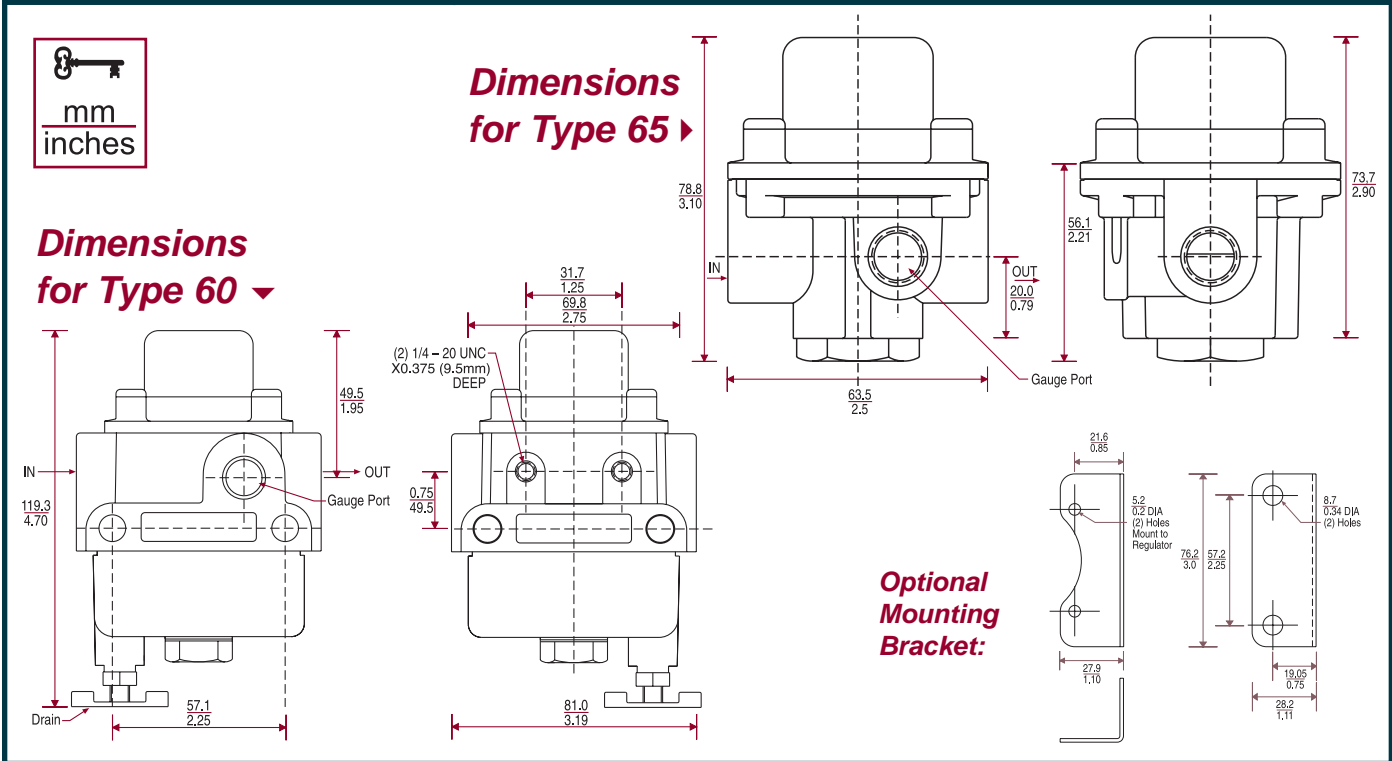

**PART NUMBERS:**

	Part Number	Port Size (NPT)	Set Point Range	
			BAR	psig
T-60	960-070-000	1/4"	0-1.4	0-20
	960-109-000	1/4"	1.4-2.8	20-40
	960-110-000	1/4"	2.8-4.1	40-60
T-65	960-071-000	1/4"	0-1.4	0-20
	960-150-000	1/4"	1.4-2.8	20-40
	960-151-000	1/4"	2.8-4.1	40-60

NOTE: Because the Types 60 & 65 are preset at the factory, it is necessary to provide the supply pressure and preset pressure setting when ordering.



*The Type 65 small stature makes it ideal for compact applications*

**OPTION ORDERING MATRIX:**

Replace last three digits of part number with digits from table below.

OPTION	1	2	4	5	7	8	10	11
1 Fluorocarbon Pintle	001	021	041	051	071	081	101	111
2 Non-Relieving		002	042	052	072	082		112
4 5 Micron Filter (T-60 only)			004	054	074	084	104	114
5 Epoxy Coating				005	075	085	105	115
7 Mounting Bracket					007	087	107	117
8 Pressure Gauge						008	108	118
10 Soft Relief Seat							010	110
11 Fluorocarbon Diaphragm								011

**OPTIONS & ACCESSORIES:**

**FLUOROCARBON PINTLE**

A special elastomeric pintle used where elements in the supply air, such as flame retardant synthetic lubricants, are particularly destructive to ordinary pintle material.

**NON-RELIEVING**

Used in applications where it is desirable to relieve pressure downstream of the regulator, for some constant flow applications, and where the gas flowing through the regulator must not escape at the regulator. Non-relieving regulators should not be used for low or no flow applications.

**5 MICRON FILTER**

Replaces the 40 micron filter supplied with the standard Type 60 for more complete air filtration. P/N 677-000-002

**CORROSIVE RESISTANT EPOXY FINISH**

An epoxy paint applied to the body, bonnet and dripwell of the regulator exterior surfaces to provide increased corrosion resistance.

**MOUNTING BRACKET**

Steel (dichromate finish) bracket for side mounting. P/N 607-000-057

**PRESSURE GAUGE**

Dual scale 2 in. (50.8 mm) gauges. Ranges include:  
 0-30 psig      0-200 kPa      P/N 625-000-001  
 0-60 psig      0-400 kPa      P/N 625-000-002  
 0-100 psig      0-700 kPa      P/N 625-000-004

When specified with a regulator, the correct range will be supplied. (NPT versions only)

**SOFT RELIEF SEAT**

Used in applications where it is desirable to reduce the standard bleed rate from 6 SCFH (2.83 LPM) to less than 0.1 SCFH (0.05 LPM).

**FLUOROCARBON DIAPHRAGM**

Diaphragm as well as all seals are made of fluorocarbon elastomer to prevent deterioration from elements in the air supply, such as flame retardant synthetic lubricants normally destructive to standard Nitrile material.

To order BSPT add "BSPT" to end of part number.

IMPORTANT NOTICE: Our recommendations, if any, for the use of this product are based on tests believed to be reliable. The greatest care is exercised in the selection of our raw materials and in our manufacturing, no guarantee or warranty, express or implied, is made as to such use or effects incidental to such use, handling or possession or the results to be obtained, whether in accordance with the directions or claimed so to be. The manufacturer expressly disclaims responsibility therefor. Furthermore, nothing contained herein shall be construed as a recommendation to use any product in conflict with existing laws and/or patents covering any material use.